

JOYEE SPA

CARE AND MAINTENANCE

CONTENTS

IMPORTANT SAFETY INFORMATION	2
SPA STORAGE.....	3
SELECTING A SITE FOR YOUR JOYEE SPA	3
ELECTRICAL REQUIEMENTS AND CONNECTIONS	5
WIRE CONNECETING	5
CHECK LIST BEFORE FILLING YOUR SPA	5
SPA WATER MAINTENANCE	5
UNCLEAN WATER TREATMENT	6
FILTER CARTRIDGE / FILTER BAG MAINTENANCE	6
SAFETY IN THE USE OF CHEMICAL PRODUCTS	8
PH ADJUSTMENT	8
DISINFECTION OF THE WATER	9
SPECIAL SPA CHEMICAL PRODUCTS	9
GUIDE TO THE USE OF THE WATER MAINTENANCE PRODUCTS	10
OZONE GENERATOR	11
SPA SHELL SURFACE CLEANING	11
LOW-USE OR NO-USE PERIODS	12
WINTERIZING YOUR SPA	12
SPA DE-WINTERIZATION	13
COVER CARE	13
DRAIN YOUR WATER.....	14



IMPORTANT SAFETY INFORMATION

When installing and using an **JOYEE spa**, basic safety precautions should always be followed, including the following:

1. Read and follow all Instructions.

2. WARNING – risk of injuries and accidental drowning to children. Children are prohibited from using JOYEE spa without adult supervision to prevent drowning and other accidents.

3. DANGER – must replace the suction fittings correctly. The suction fittings in JOYEE spa are sized to match the specific water flow created by the pump. If replacement of suction fittings or pump is required, make sure the flow rate is consistent. If the suction fittings is damaged or lost, please do not operate JOYEE spa and use it after replacing the suction fittings.

4. DANGER - risk of electric shock. Do not permit any electric appliance, such as a light, telephone, radio or TV, within 5 feet (1.5m) of the JOYEE spa.

6. WARNING - to reduce the risk of injury:

- a) Before entering the spa, check the temperature first.
- b) Since excessive water temperatures have a high potential for causing fatal damage during the early months of pregnancy, pregnant or possibly pregnant women should seek advice before using the spa and should maintain safe water temperatures.
- c) The use of alcohol, drugs or medication before or during spa use may lead to unconsciousness with the possibility of coma.
- d) Persons suffering from obesity or with a medical history of heart disease, low or high blood pressure, circulatory system problems, or diabetes should consult a physician before using spa.
- e) Persons using medication should consult a physician before using the spa since some medication may induce drowsiness while other medication may affect heart rate, blood pressure and circulation.

ADDITIONAL SAFETY INSTRUCTION:

1. WARNING - risk of fatal hypothermia.

- a) The use of alcohol, drugs, or medication can greatly increase the risk of fatal Hypothermia in the spa.
- b) The causes, symptoms, and effects of Hypothermia may be described as follows: Hypothermia occurs when the internal temperature of the body reaches a level several degrees above the normal body temperature of 37°C (98.6°F). The symptoms of Hypothermia include an increase in the internal temperature of the body, dizziness, lethargy, drowsiness, and fainting. The effects of Hypothermia include:
 - Unawareness of impending hazard;
 - Failure to perceive heat;
 - Failure to recognize the need to exit the spa;
 - Physical inability to exit the spa;

- Fatal damage to pregnant women;
 - Unconsciousness and danger of drowning.
- 2. WARNING - risk to infants, elderly, and women planning pregnancy or during pregnancy.** Please consult your physician if the above applies to you or anyone using your spa.
 - 3. WARNING - risk of children drowning.** Although your JOYEE spa cover is not rated as a safety cover, it is better to always keep the spa cover securely fastened when not in use. This will help discourage children from attempting to enter the spa when not supervised by an adult.
 - 4. WARNING - risk of drowning.** Use caution when bathing alone. Overexposure to hot water may cause nausea, dizziness, and fainting.
 - 5. WARNING - risk of injury.** Always use extreme caution while entering or exiting the spa. Surfaces can be very slippery when wet. Do not step on or sit on head rests. Keep all breakable objects out of the spa area.
 - 6. WARNING - risk of injury.** Never use the spa immediately after strenuous exercise.
 - 7. WARNING - risk of injury.** Individuals with infectious diseases should not use the spa.
 - 8. WARNING - risk of injury.** Maintain water chemistry in accordance with chemical manufacturer's instructions.
 - 9. WARNING - risk of shock.** The spa shall not be operated in severe weather conditions, i.e. electrical storms.
 - 10. CAUTION - unauthorized access.** Secure the spa area against unauthorized access. Make sure all barriers meet local codes. Keep the spa cover on spa when not being used.
 - 11. CAUTION - risk of damage to spa or equipment.** By performing maintenance as described later in this Owner's Manual, the chance of damage to your spa and it's equipment will be greatly reduced.
 - 12. CAUTION - non-approved accessories.** Using accessories not approved by the manufacturer could void your guarantee or cause other problems. Please consult with your authorized JOYEE dealer.
 - 13. CAUTION - location of your JOYEE spa.** Locate your spa on a surface that can withstand the weight bearing requirements of the spa. Also, locate your spa in an environment that can withstand repeated exposure to water and the possibility of a major spill.

SPA STORAGE

The skirt of hot tub will be deformed at 60-70 degrees. If it is placed outdoors without removing the package, it will be deformed. Because the packing foam will heat up after being exposed to the sun. Please place the unpacked hot tub in a cool indoor place, and do not expose it to the sun. If it is placed outdoors, please remove the package.

SELECTING A SITE FOR YOUR JOYEE SPA

Your JOYEE spa was designed for either indoor or outdoor use. Whether indoors or outdoors, please adhere to the following guidelines:

1. Select a site that is stable and capable of supporting the weight of your spa, its water, and the people using it (refer to the model brochure or contact an authorised JOYEE dealer for the filled weight of your spa). If installed on a suspended floor/deck, the floor/deck should be capable of supporting your spa. If you have concerns on this matter, please contact a qualified licensed contractor.

2. Select a surface that is flat and level. This surface must provide continuous support for the entire bottom of the spa structure. Do not shim or block up the spa creating voids below the base framework. If you do not intend to use a pit please ensure you have adequate drainage or a soak away.

3. Avoid installing the spa in a pit or low area where water may accumulate and damage the spa or its equipment. Choose a site where water will drain away from the spa and not towards it.

4. IMPORTANT: With all installations, the JOYEE spa must be located at least 150cm [5 feet] from all electrical outlets, switches, and other permanently installed electrical devices.

INDOOR CONSIDERATIONS: There are several considerations when installing your JOYEE spa indoors: the environment both around and below spa should be water resistant. It must be capable of handling water splashed out from the spa; it is recommended that the room you install the spa in has proper ventilation. Proper ventilation can usually be achieved by an exhaust fan or a dehumidifier if spa is used for less than one hour per day.

NOTE: Typical indoor surfaces include, but are not limited to: concrete, wood, non-slip tile or linoleum.

OUTDOOR CONSIDERATIONS: When selecting an outdoor site, several things should be considered.

Firstly, avoid selecting a site where excessive water may contact the spa such as from sprinklers or a roof edge without rain gutters. If possible, avoid areas of direct, prolonged sunlight. The ultraviolet rays of sunlight will tend to fade and damage your JOYEE spa cover and cabinet.

Lastly, avoid locating your spa in an area where debris could be blown into the spa. If sinking your JOYEE spa into the ground a suitable drainage system must be installed to avoid the risk of hydrostatic pressure from rising ground water.

NOTE: Typical outdoor surfaces include, but are not limited to: concrete, brick, non-slip tile, wood-decking, pea shingle or sand.

UNLOADING: The standard packaging of the spa is vertical packaging, when you lay down the spa:

- 1) Please confirm which side is above.
- 2) Please place foam or shock absorbing materials on the ground to avoid impact when the spa falls.

ELECTRICAL REQUIEMENTS AND CONNECTIONS

All JOYEE spas must be wired in accordance with all national electric codes. Always use a qualified electrician to perform the electrical installation.

WARNING: Operating the system without water will cause severe damage.

WARNING: SHOCK HAZARD! No user serviceable parts. Do not attempt to service this control. Contact your dealer or service center for assistance. Follow all user's manual power connection instructions. Installation must be performed by a certified licensed electrician and all grounding connections must be properly installed.

WIRE CONNECETING

Please open the spa skirt according to instruction on it, connect the power supply correctly. If the power supply is 220V/50HZ, the wires serving as equipotential bonding conductors shall have a cross sectional area not less than 3x10 mm². If the power supply is 380V/50HZ, the wires serving as equipotential bonding conductors shall have a cross sectional area not less than 5x6 mm². The protection system should be based on a residual current device (RCD). Be sure that the earth cable connection is correctly made. The circuit diagram of spa is shown on the cover of the control box. For more details, please refer to the control system tech sheet.

IMPORTANT INFORMATION

Never, under any circumstances, install your spa on an electrically heated floor.

CHECK LIST BEFORE FILLING YOUR SPA

IMPORTANT: The spa should never be operated without water in the spa. Serious damage to the spa will occur.

- 1. Installing your cover:** Your JOYEE spa cover comes with tie-down straps and locking hardware to attach the cover to the spa cabinet or decking.
- 2. Check drain valves:** Check that the spa drain valve is fully closed.
- 3. Tighten equipment fittings:** Hand-tighten all PVC pipe unions, pump unions and pump drain plugs to prevent the possibility of leakage (sometimes these fittings loosen during shipment). Check also that all fittings on the filter are closed (HAND TIGHT ONLY!).
- 4. Check valve:** Verify that all valves aside from the drainage valves described previously are in the fully open position. A valve that is half closed will result in a noisy pump due to lack of water flow.
- 5. Fill the spa:** Fill the spa to approximately the halfway point on the skimmers. Because standard spa without water inlet, please put the water pipe into the skimmers directly. Please do not put the water pipe into the spa directly to avoid the air come into the pump.

note 1: The higher the water level, the less pool users. it will take to cause the water to overflow the pool edge.

6. Check for leaks: After the JOYEE spa is full, but before turning the power on, check all the

fittings and equipments for signs of leakage. If a leak is detected, except from fittings that can be hand-tightened, call your authorised JOYEE dealer.

SPA WATER MAINTENANCE

The user must pay particular attention to the maintenance of water. Water can accumulate impurities that can worsen the performance or damage the filtration system if chemicals are not applied on a regular basis. The water can even become unhealthy if chemicals are not used appropriately. Improper pH levels or calcium levels can cause either corrosion of parts or scale build-up. Maintenance will depend on the mineral content of the water used, how often the Spa is used and how many people use the Spa.

There are three essential points for the maintenance of the water:

- FILTERING OF WATER
- pH CONTROL
- SANITIZATION OF WATER

UNCLEAN WATER TREATMENT

Keep the water clean and sanitized with correct chemical care. The recommended levels for your JOYEE spa are:

Chlorine: 3 - 5ppm

Water pH: 7.2 - 7.6

Calcium Hardness: 250-500ppm

Alkalinity: 125 -150ppm

IMPORTANT:

1. Turn on the clean cycle when adding any spa water chemicals into or in front of the filter compartment.
2. Check and clean the skimmer basket at least every four weeks to ensure proper filter flow.
3. Clean the filter cartridge / filter bag at least every four weeks to remove debris and mineral buildup.
4. Change the water four times a year to keep the water clear over a long periods of time

FILTER CARTRIDGE / FILTER BAG MAINTENANCE

The filter cartridge / filter bag needs to be checked, cleaned and replaced regularly. It is very important to keep proper water flow. A clean filter cartridge / filter bag enables the hydrotherapy system to work properly and allows for more efficient filter cycles. Depending on the usage frequency of the spa, we recommend cleaning the spa filter cartridge / filter bag every four weeks. If this is not done, the filter may block and restrict water flow, which causes improper filtration, poor jet performance and may possibly freeze.

IMPORTANT: The cleaning frequency of the filter cartridge / filter bag is depends on the swim spa use frequency and number of users. More use means that more frequent filter cartridge cleanings will be required.

Filter cartridge removal and replacement

Turn off the power supply and process as follows:

1. Remove the filter cover.

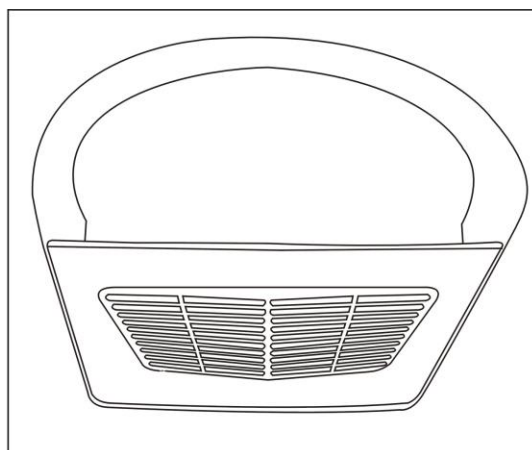
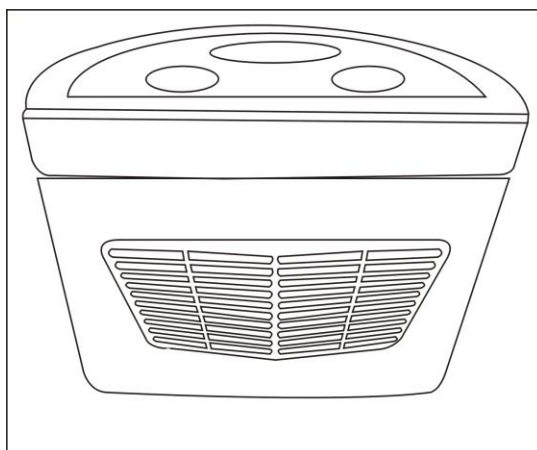

2. Twist the filter cartridge and take it out.

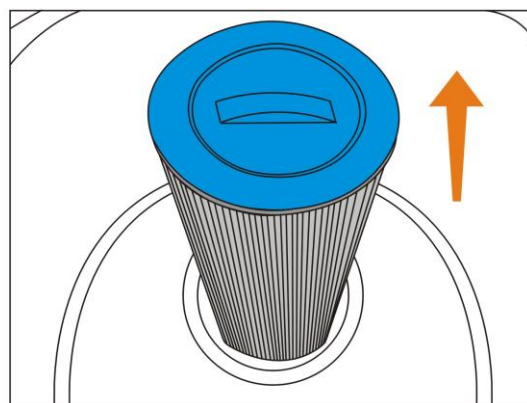
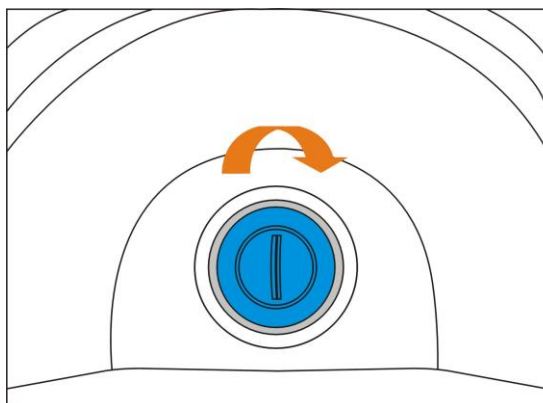

3. Place a new filter cartridge into the filter cylinder.

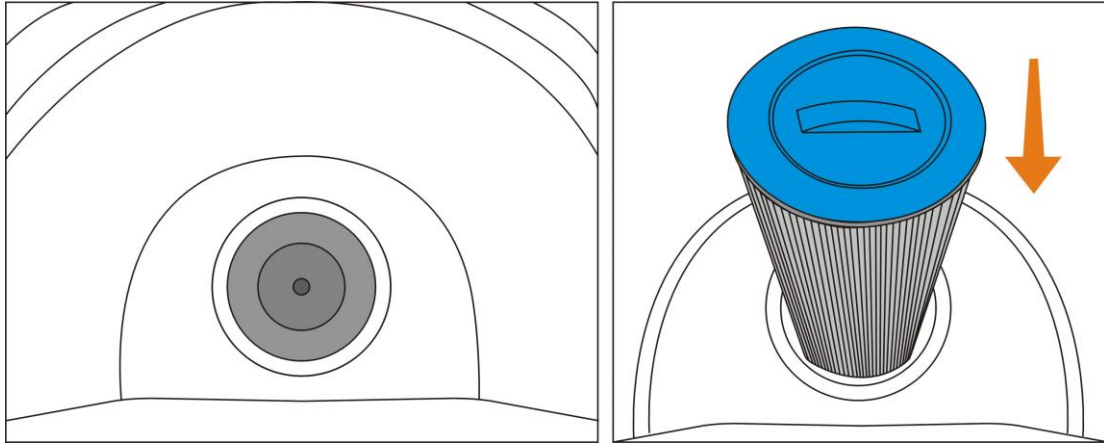

4. Put the filter cover back.

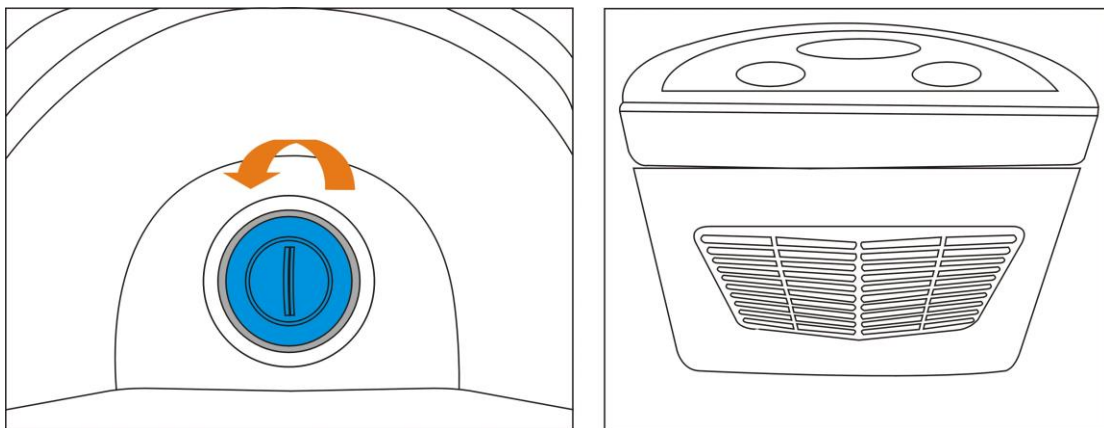

Filter cartridge / filter bag cleaning

Only using water to clean the filter cartridge / filter bag is enough. We recommend at least one extra filter cartridge / filter bag should be kept in stock. The filter cartridge / filter bag can be used only after drying, during the drying procedure, an extra filter cartridge / filter bag is needed for the replacement, in order to avoid interrupting the normal running of filtration systems.

SAFETY IN THE USE OF CHEMICAL PRODUCTS

Before using a chemical product, read the instructions on the product label carefully.

IMPORTANT:

1. It is advisable that always the same person handles the chemical products. Keep these products away from children.
2. Keep containers tightly closed in dry, well-ventilated places.
3. Do not inhale chemical products, and take care not to let them come into contact with the eyes, nose or mouth. Wash hands after use.
4. Follow the emergency instructions on the product label in the event of an accident or

ingestion.

5. Do not smoke while handling these products, they may be flammable.
6. Do not store these products inside the Spa unit. Store chemicals in a cool, dry, clean place.
7. Never mix products. Add first one and then the other to the water, to avoid possible reactions.
8. Do not add chemical products to the water if there is someone in the Spa.

PH ADJUSTMENT

A pH index of between 7.2 and 7.6 is recommended.

The pH level measures the acidity and alkalinity: Values above 7 are alkali and below 7, are acid.

IMPORTANT: It is very important to maintain the correct pH level both for the disinfectant to work properly and to prevent corrosion or deposits on the Spa. Any damage caused by an inadequate pH level is not covered by your Spa guarantee.

1. The effects of a very low pH level are:

- The disinfectant will quickly dissipate.
- The equipment of the Spa become rusty.
- The water can start causing skin irritations to bathers.

2. The effects of a very high pH level are:

- The disinfectant is less effective.
- Scale may appear on the acrylic and equipment.
- The water may become cloudy.
- The filter cartridge/ filter bag can become blocked.

Check the pH of the Spa water daily using the pH test set.

If the pH is above the indexes, use pH MINOR cleaner. Wait for two hours and re-do the pH test.

If the pH is below indexes, use pH MAJOR cleaner. Wait for two hours and re-do the pH test.

Once the pH index has been adjusted to the values indicated above, proceed to the next point.

DISINFECTION OF THE WATER

Disinfection of the water is of utmost importance in order to destroy algae, bacteria and organisms that could develop in the water. However, excessive disinfection could cause skin and eye irritation.

CHLORINE TABLETS are a suitable disinfectant for the Spa water. This product is placed in the prefilter and gradually dissolves.

Check the residual chlorine level daily using the Br analyser set.

The recommended level of residual chlorine is between 2.2 and 3.3 ppm.

SPECIAL SPA CHEMICAL PRODUCTS

Apart from products to maintain the pH and disinfectant level, there are other products formulated especially for use in Spas that will help you to maintain the water and installation in perfect condition.

- **ANTI-SCALE:** This prevents the precipitation of calcium salts (scale), particularly in hard water. This product should be added weekly and whenever the water is renewed.
- **ANTI-ALGAE:** This algacide prevents algae from growing in the Spa water. This product is added weekly and whenever the water is renewed.
- **DEGREASER:** To remove rings of dirt and grease that form on the walls of the Spa. To use this product, it is recommended to empty the Spa and apply a degreaser with a sponge on the parts to be cleaned. Rinse immediately with plenty of water.

GUIDE TO THE USE OF THE WATER MAINTENANCE PRODUCTS

Products	Reason for use	Dosage	Frequency of use
Debris & Dust cleaner	To clean the debris or dust adhere to the spa bottom or the jets		Use the JOYEE cleaning kit once a week
pH minor cleaner	The pH level is below the acceptable level	Following the recommendations of the chemical product manufacturer	Analyze daily with the pH Test
pH major cleaner	The pH level is below the acceptable level	Following the recommendations of the chemical product manufacturer	Analyze daily with the pH Test
Chlorine tablets	The Br level is above the acceptable values(3-5ppm)	Following the recommendations of the chemical product manufacturer	Analyze daily with the Br Test
Anti-scale cleaner	To prevent precipitation of water scale	Following the recommendations of the chemical product manufacturer	Once a week and fill the new water
Anti-algae cleaner	prevent algae from growing in the water	Following the recommendations of the chemical product manufacturer	Once a week and fill the new water

JOYEE SPA CARE AND MAINTENANCE

Degreaser	to clean rings of dirt on the walls of the spa	Following the recommendations of the chemical product manufacturer	Whenever dirt is observed on the walls of the spa
Ozone		Ozonizer runs on FILTER CYCLES	

NOTE: Any time you add a chemical, turn the jets on to help dissolve it appropriately.

OZONE GENERATOR

Ozone, O₃, is an oxidizing chemical compound, which is very effective for disinfecting water. The main advantage of ozone is that it leaves no chemical trace and is odourless. The capacity of ozone as a disinfectant is due to its potential as an oxidizing agent, which eliminates any organic matter that may be present in the water.

In order to produce ozone, electricity is passed through an ozonizer to produce ozone ions from oxygen in the atmosphere. This is an automatic process and the resulting product is injected through the jets of the Spa. The process does not require the user to use any other mechanism.

The water is collected in the drains and skimmer, by the absorption action of the massage pump.

It is then sent through the heat exchanger and as it leaves, the ozone is injected. The water is distributed by the filtering back-flow. Part of this flow is also distributed through the drain outlet in order to avoid stagnant water from collecting.

Ozone treatment does not exclude the use of other chemical products such as Chlorine or Bromide.

Ozone is considered a complementary process to them, therefore reducing the use of Chlorine or Bromide.

SPA SHELL SURFACE CLEANING

Gently rub the spa shell surface with a sponge or a soft towel to wipe off the dirt. Soap or detergent could be used if necessary.

Note:

1. **DO NOT USE** scouring pad or corrosive cleaning powder to clean the spa shell surface.
2. **DO NOT ALLOW** any strong organic solvents (formic acid and formaldehyde products),

such as paints, solvents, volatiles and diluents to contact the spa, which might lead to spa shell surface softening, dissolving, cracking and so on. These phenomena will endanger the quality of the spa.

3. **DO NOT** put rusty items (such as rusty cleaners) into the spa, otherwise the jets will be oxidized and rusted.

4. Shower gel and shampoo are organic compound gels, which are not very soluble in water. Due to the existence of organic property, electric charge will attract heterosexual dust particles to gather, float over the water, or sink at the bottom. Floating over the water will adhere to the filter bag or filter cartridge, which will cause blockage. Sediment at the bottom will cause flocculation, which will make the water quality go bad.

LOW-USE OR NO-USE PERIODS

At certain times of the year you may not use your spa as often as expected. For these low-use or no-use periods, we recommend the following:

Low-use:

If your spa is being used less than once per month, then you may wish to lower the temperature setting by approximately 10°C. Lowering the temperature on your spa will cut your cost of operation if you are not using the spa for extended periods

No use for 1-2 weeks:

If you plan to not use your spa for one-two weeks, then we suggest that you not make any changes in operating your spa.

no use for 2-6 weeks:

If you plan to not use your spa for two-six weeks, then you may wish to lower the temperature setting to approximately 26°C during the No-Use period.

no use for over 6 weeks:

If you plan to not use your spa for over six weeks, then it is suggested that you winterize your swim spa by taking the following steps:

WINTERIZING YOUR SPA

If you leave the spa unused for a long period of time in severely cold weather, you should drain the spa and winterize it to avoid accidental freezing due to a power or equipment failure.

1. Drain your spa following the “Draining Your Spa” instruction.
2. Remove the filter cartridge/filter bag, clean and store in a dry place.

IMPORTANT: These additional instructions must be utilized when draining and

winterizing your spa in climates where the temperature falls below 32°F (0°C). A five (5) gallon combination (vacuum/blower) wet/dry shop vac must be used to effectively remove water that is trapped inside the plumbing lines.

3. Attach the vacuum hose to the vacuum side of the shop vac. vacuum all openings and orifices as follows:

a. Jet openings: start with the jets at the top and move downward (if suction is coming from another jet, block off the other jet using a large rag – this will help pull out the water that is trapped deeper inside the main line).

b. Filter suction fittings and filter compartment.

c. Main drain outlet (it may be necessary to cover the drain grate tightly with a rag when vacuuming the main drain to ensure water is drawn completely from the internal plumbing system).

4. Drain the spa equipment. This is done by removing the drain plug from the pumps, loosening all PVC pipe unions.

5. Thoroughly dry the spa shell with a clean towel.

6. Close the spa cover and fasten the cover tie downs. Cover the spacover with two pieces of plywood to evenly distribute the weight of snow and ice. Secure a plastic sheet, or tarp, over the spa cover and plywood.

SPA DE-WINTERIZATION

De-Winterisation is completed by reversing the above procedure and then refilling the spa.

Note: If your spa water is not emptied during periods of No-Use, you should test and chemically treat the water approximately once per week. Not doing so may lead to corrosion, staining and/or scaling to your spa and its equipment. If there is no one available to take care of the spa on a weekly basis, then it is recommended that you winterise your swim spa as described above.

COVER CARE

The vinyl spa cover is an attractive, durable foam insulation product. Monthly cleaning and conditioning are recommended to maintain its beauty.

TO CLEAN AND CONDITION THE VINYL COVER:

SERVICE NOTE: To remove tree sap, use cigarette lighter fluid (not charcoal lighter fluid). Use sparingly, and rinse with a saddle soap solution immediately afterwards, then wipe dry.

IMPORTANT REMINDERS:

- DO remove snow buildup to avoid breakage of the foam core from the additional weight of the snow.
- DO lock cover lock straps to secure the cover when the spa is not in use.
- DO NOT drag or lift the spa cover using either the flaps or the cover lock straps.
- DO NOT walk, stand, or sit on the cover.
- DO NOT place any metal or heat transferring object on the cover or place any type of plastic tarp or drop cloth over the cover as this may result in a melted foam core, which would not be covered under the warranty.

DRAIN YOUR WATER

1. Turn off the power supply and GFCI breaker (if installed).
2. Pull the handle and take it out, then remove the drain cap.
3. Connect a hose to the drain tube. If your hose is small, the reduction will be helpful. Just connect the reduction and the hose.
4. Open the skirt panel a side the drain valve to open the red ball valve inside the spa (the ball valve connecting to the black drain valve is closed when it is out of factory). Then the water will come out.
5. After the swim spa is empty, clean the shell and filter cartridge. If you need to dry the water completely, please activate the air blower running for a while to drain the water in the air pipeline.
6. Close the red ball valve inside the swim spa. Then remove the hose and reduction (if used it) and cover the drain cap back. Last, push the handle back into the drain valve.